

# SJ3220/26

## ELECTRIC SCISSORS



### STANDARD FEATURES

- Drivable at full height
- Variable speed, rear two wheel hydraulic drive
- Dual holding brakes
- SKYCODED™ Color coded and numbered wiring system
- On-board visual interface with diagnostic capabilities
- Shroud style, impact resistant composite control box with extended cable
- Proportional controls for drive & lift functions
- Tilt sensor (3.5° x 1.5°)
- 3' (0.91 m) Roll out extension deck
- 24V DC Power source
- Low voltage battery protection
- 25% Gradeability
- Solid rubber, non-marking tires
- Pothole protection system
- 110V AC Outlet on platform with GFI
- 28 mph (12.5 m/s) Wind rating (SJ3226 to 18' 6" (5.63 m))
- Tilt alarm with drive & lift cut-out
- All motion audible alarm
- Lanyard attachment points
- Operator horn
- Forklift pockets and tie down/lift lugs
- Overload sensing system
- Fold down hinged railing system
- Half height spring hinged entry gate
- Telematics ready
- 2-Year Gold Leaf Warranty (5-year structural warranty)

### OPTIONS

- Light duty pipe rack
- Heavy duty pipe rack
- Board carrier
- Tool caddy
- Flashing light
- Dual flashing lights
- 6' (1.8 m) Powered ext. deck (SJ3220)<sup>‡</sup>  
<sup>‡</sup>adds 387 lbs (176 kg) to unit weight and reduces overall capacity to 800 lbs (363 kg)
- 800W AC Inverter
- 250 Ah Batteries (cannot be combined with EE rating package)
- AGM Batteries
- Lockable swingout trays
- EE Rating package (not available with telematics keypad)
- Full height spring hinged entry gate
- Bio oil
- Secondary Guarding Lift Enable (SGLE)
- Non-destructive testing
- ECOTRAY leak containment system (SJ3226 only)
- ELEVATE telematics (3-year or 5-year plans available)
- ELEVATE Battery Management System (BMS)\*
- Warranty options (3-year or 5-year plans available)

† Standard lead times may be increased when optional equipment is added, consult factory.

‡ Capacities and machine weights may differ when options are added.

\* Only available with ELEVATE telematics

# SJ3220/26 ELECTRIC SCISSORS

Dimensions	SJ3220	SJ3226
<b>A</b> Work Height	25' 6" (7.77 m)	31' 7" (9.63 m)
<b>B</b> Raised Platform Height	19' 6" (5.95 m)	25' 7" (7.79 m)
<b>C</b> Lowered Platform Height	39" (0.99 m)	46" (1.17 m)
<b>D</b> Overall Width	32" (0.81 m)	32" (0.81 m)
<b>E</b> Overall Length	91.6" (2.32 m)	91.6" (2.32 m)
<b>F</b> Stowed Height (Rails Up)	83" (2.10 m)	90" (2.29 m)
<b>G</b> Stowed Height (Rails Down)	69" (1.75 m)	76" (1.93 m)
<b>H</b> Platform Width (Inside Dimension)	28" (0.71 m)	28" (0.71 m)
<b>I</b> Platform Length (Inside Dimension)	83" (2.11 m)	83" (2.11 m)
Specifications	SJ3220	SJ3226
Extension Deck (Roll Out)	3' (0.91 m)	3' (0.91 m)
Ground Clearance (Pothole Raised)	4.0" (10.2 cm)	4.0" (10.2 cm)
Ground Clearance (Pothole Deployed)	0.5" (1.3 cm)	0.5" (1.3 cm)
Wheelbase	69" (1.75 m)	69" (1.75 m)
Weight	3,917 lbs (1,776 kg)	4,190 lbs (1,900 kg)
Gradeability	25%	25%
Turning Radius (Inside)	43" (1.09 m)	43" (1.09 m)
Turning Radius (Outside)	104" (2.64 m)	104" (2.64 m)
Lift Time (With Rated Load)	28 sec	47 sec
Lower time (With Rated Load)	24 sec	41 sec
Drive Speed (Stowed)	2.4 mph (3.9 km/h)	2.4 mph (3.9 km/h)
Drive Speed (Raised)	0.6 mph (1.0 km/h)	0.6 mph (1.0 km/h)
Maximum Drive Height	Full Height	Full Height
Capacity (Overall)	900 lbs (408 kg)	500 lbs (227 kg)
Distributed Capacity (Main Platform)	600 lbs (272 kg)	250 lbs (113 kg)
Distributed Capacity (Extension Deck)	300 lbs (136 kg)	250 lbs (113 kg)
Local Floor Load (With Rated Load)	109 psi (749 kPa)	104 psi (718 kPa)
Overall Floor Load (With Rated Load)	248 psf (1,209 kg/m <sup>2</sup> )	241 psf (1,177 kg/m <sup>2</sup> )
Maximum # of persons at 0 mph (0 m/s) wind rating	2	2
Maximum # of persons up to 28 mph (12.5 m/s) wind rating	1	1 up to 18' 6" (5.63 m)
Tire Type	Solid, N/M	Solid, N/M
Tire Size	16 x 5 x 12	16 x 5 x 12

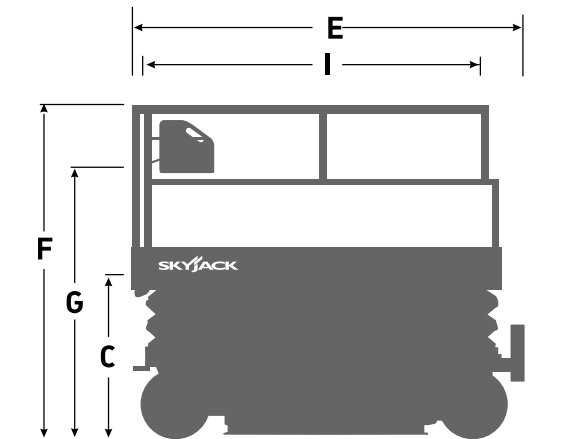
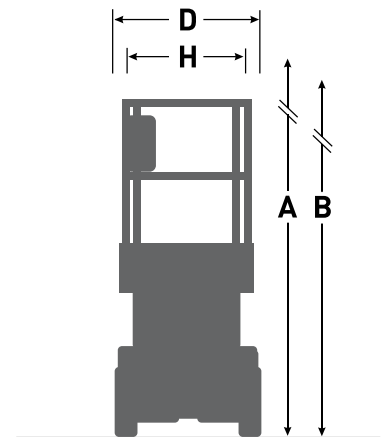

Fimatec Equipamentos  
 Rua Ismael da Rocha, 162 - Ramos, Rio de Janeiro - RJ  
 CEP 21031-050 - [www.fimatecequipamentos.com.br](http://www.fimatecequipamentos.com.br)

